

DESCRIPTION

These surface fixtures are designed with molded trim in a high tech, brushed nickel finish and a smooth white drop dish style diffuser. Available in three sizes which use (2) 48" lamps, (4) 48" lamps or (2) 6" U lamps.

CONSTRUCTION

Housing, cover and ends are die formed of 20 gauge cold rolled steel. Standard mounting holes and standard wiring knockouts are included, with an extra 2" diameter center knockout on the back for wiring entry.

FINISH

Housing interior and exterior are finished in lighting grade white baked gloss enamel paint.

DIFFUSER

Lens is a one-piece extruded smooth flat lens of translucent white 100% virgin acrylic, .100" thick. The lens is scored mitered and formed into the box cloud shape. Trim bands are made of extruded expanded polymer, with a brushed nickel mylar finish, and are glued and screwed to the box cloud. The entire frame/cloud attaches to the housing with a pre-installed bracket inside one end and one #8 screw through other end.

ELECTRICAL

All units with model numbers ending in ES are wired with U.L. listed high power factor, rapid start, Class P, energy saving (ES) full light output, E ballasts, for 120 volt, 60 hertz A.C. operation. Lampholders are rotating lock, medium bi-pin type. All fixtures are U.L. listed.

OPTIONS

For ballast upgrades and options, refer to back of guide. Other voltages, listings, and ratings available on request (contact factory).

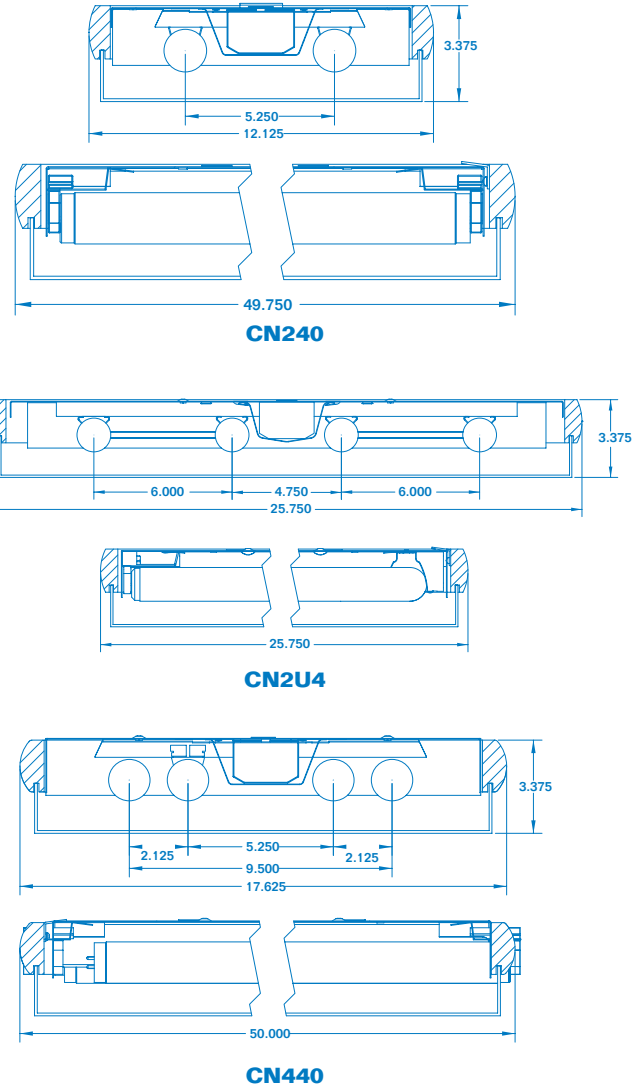

ORDERING INFORMATION

DIMENSIONS

Model No.	Fluorescent Lamps	L	W	D	Mtg. Ill.
CN240ES	(2) T12 48" Lamps	49 ³ / ₄ "	12 ¹ / ₈ "	3 ³ / ₈ "	70
CN2U4ES	(2) T12 6" U Lamps	25 ³ / ₄ "	25 ³ / ₄ "	3 ³ / ₈ "	74
CN440ES	(4) T12 48" Lamps	49 ³ / ₄ "	17 ⁵ / ₈ "	3 ³ / ₈ "	73