

DESCRIPTION

These economical, low profile, narrow style wrap fixtures are designed in a variety of lamp combinations to meet your needs. All units use T8 or T12 lamps.

CONSTRUCTION

Housing and cover are die formed of 22 gauge cold rolled steel. Standard mounting holes and standard wiring knockouts are included, with an extra 2" diameter center knockout on the back for wiring entry. Fixtures can be stem, chain, or direct mounted. They can be hung individually or in continuous runs.

FINISH

Housing interior and exterior are finished in lighting grade white baked gloss enamel paint.

DIFFUSER

Lens is a one-piece extruded lens of clear 100% virgin acrylic, .090" thick, with a diamond prismatic pattern. The lens lifts and shifts into the housing

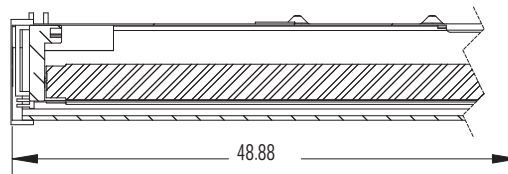
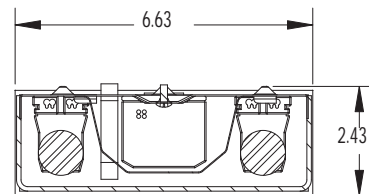

ELECTRICAL

All units are wired with U.L. listed Electronic, Normal power factor, Rapid start, Class P, full light output ballast for 120 volt, 60 hertz A.C. operation. 0°F minimum starting temperature. Ballast operates* F25T12, F32T8, F34T12 or F40T12 lamps. Lampholders are rotating lock, medium bi-pin type. All fixtures are U.L. listed for consumer use.

OPTIONS

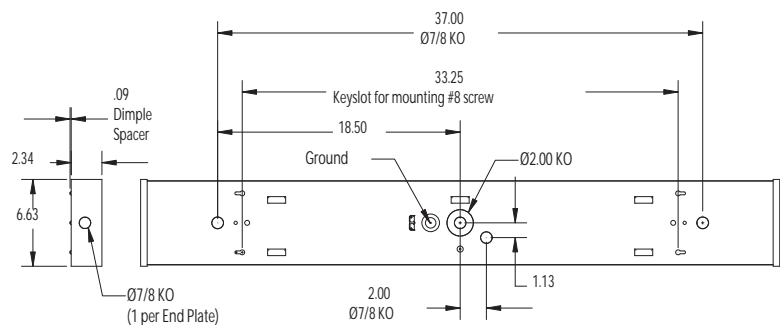

ORDERING INFORMATION

DIMENSIONS

Model No.	Fluorescent Lamps*	L	W	D	Mtg. Ill.
SW232RC	(2) F32T8 48"	48 7/8"	6 5/8"	2 7/16"	

ENERGY STAR compliant when used with F32T8 lamps, >75 CRI and ≥2185 lumens.

